



**Politechnika Łódzka**  
Instytut Inżynierii Materiałowej

Łódź, dnia 24.08 2006

**MOTO SZLIF S.C.**  
**K. Leszczyński, R. Urbanek -**  
**Leszczyńska**  
**91-370 Łódź ul 11-listopada 3**

**ŚWIADECTWO BADANIA nr I-7/1/16-2/2006 NU**  
**Wyników obróbki cieplnej odlewów komór wirowych ze staliwa LH 14**

**Wykonano badania:**

1. Twardości metodą Rockwela wg PN EN ISO 6508-1 na reprezentatywnej dla rozłożenia wsadu ilości elementów obrabianych.
2. Struktury uzyskanej w wyniku obróbki cieplnej na losowo wybranym elemencie z obrabianego wsadu.

**Wyniki badań:**

1. Twardość elementów wynosi 29÷31 HRC  
Twardościomierz: KP15002P
2. Mikrostruktura przedstawiona jest na fotografii.  
Mikroskop AXIOTRON



material  
po obróbce cieplnej

Struktura:  
Sorbit z zaznaczonym  
pomartenzycytnym układem  
iglastym.

Pow: 1000×  
Trawienia: Mi1Fe

Badania wykonał:

  
Mgr inż. Antoni Rzepkowski



Instytut Inżynierii Materiałowej

90-924 Łódź, ul. Stefanowskiego 1/15 budynek A18  
tel. 042 631 22 79 fax 042 636 67 90, e-mail: s-17-1@iir.p.lodz.pl



**Politechnika Łódzka**  
Instytut Inżynierii Materiałowej

Lodz, 24.08.2006

**MOTO SZLIF S.C.**  
**K. Leszczyński, R. Urbanek -**  
**Leszczyńska**  
**91-370 Łódź ul 11-listopada 3**

**TEST CERTIFICATE no I-7/1/16-2/2006 NU**

**The heat treatment of swirl chamber castings made of LH14 cast steel**

**Tests made:**

1. Rockwell hardness test according to PN EN ISO 6508-1 for amount of treated elements representative for charge distribution.
2. Structure obtained as a treatment result, observations of randomly chosen element, from the whole charge

**Test results:**

1. Hardness of the elements: 29÷31 HRC  
Hardness tester: KP15002P
2. Microstructure shown in the figure.  
Microscope: AXIOTRON



material  
after heat treatment

Structure:  
Sorbite with depicted postmartensitic  
aciform configuration

Mag: 1000×  
Etchant: Mi1Fe

Test were performed by:

  
Antoni Rzepkowski, MSc.



Instytut Inżynierii Materiałowej

90-924 Łódź, ul. Stefanowskiego 1/15 budynek A18  
tel. 042 631 22 79 fax 042 636 67 90, e-mail: s-i7-1@sir.p.lodz.pl

# MOTO-SZLIF<sup>®</sup> S.C.

## komory wirowe

---

### WYMIARY

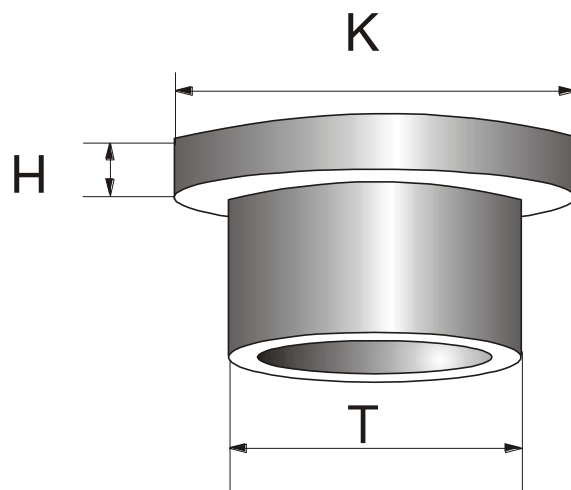



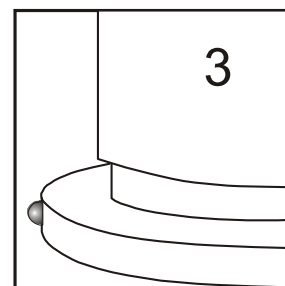
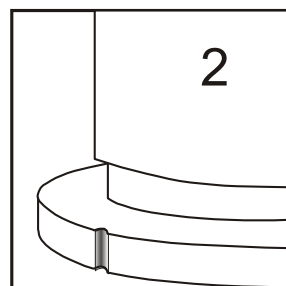
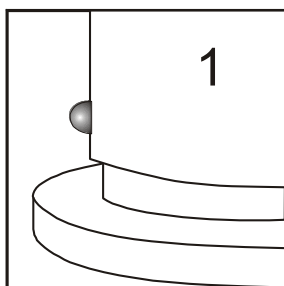





### POZYCJONOWANIE









# MOTO-SZLIF®

## komory wirowe

Model	Photo	Code engine	Engine Capacity cm <sup>3</sup>	qty cylinder	Moto Szlif Nr	K Ø mm	T Ø mm	H Ø mm	opening length (mm)	poz
<b>Alfa Romeo</b>										
2000TD, 164D 2400TD, 164TD 2500TD		VM80A VM81A VM84A	2400	4	0205G	35,60	30,40	4,8	12	1
					0205H	36,00	30,40	5,0		
<b>Audi</b>										
80D 80TD 90D/TD		GR ME/MF/SB	1600	4	0803A	30,10	25,40	4,3	11,5	1
					0803B	30,50	25,40	4,6		
80D/TD 90D/TD		JK/CY JP/JR	1600	4	0101A	32,10	27,40	4,3	11,5	1
					0101B	32,20	27,40	4,4		
					0101C	32,50	27,40	4,6		
80D/TD		1Y AAZ AEY	1900	4	0102A	32,10	27,90	4,3	12,5	1
					0102B	32,20	27,90	4,4		
					0102C	32,50	27,90	4,6		
100D 100Avant		3D AAS	2400	5	0101D	32,10	27,90	4,3	11,5	1
					0101E	32,20	27,90	4,4		
					0101F	32,50	27,90	4,6		
<b>Bertone</b>										
Freeclimber TD		M21D	2400	6	0802A	31,00	27,50	4,3	11	1
					0802B	31,50	27,50	4,6		
<b>BMW</b>										
324d/td		246D	2400	6	0802A	31,00	27,50	4,3	11	1
		246T	2400		0802B	31,50	27,50	4,6		
325td		256T	2500							
524d/td		246D	2400							
525td		246T	2400							
		256T	2500							
<b>Chrysler</b>										
Voyager		VM D/TD	2400	4	0205G	35,60	30,40	4,8	12	1
					0205H	36,00	30,40	5,0		









# MOTO-SZLIF®

## komory wirowe

Model	Photo	Code engine	Engine Capacity cm <sup>3</sup>	qty cylinder	Moto Szlif Nr	K ∅ mm	T ∅ mm	H ∅ mm	opening length (mm)	poz
<b>Citroen</b>										
BX19 BX19RD BX19TRD ZXD Xantia Evasion Jumpy Jumper Berlingo		XUD9 XUD9A/L XUD9TE	1900	4	<b>0104A</b>	32,15	28,10	4,2	11,5	1
					<b>0104B</b>	32,65	28,10	4,5		
Xantia XM		XUD11	2100	4	<b>0205C</b>	34,10	29,80	4,2	12	1
					<b>0205D</b>	34,50	29,80	4,5		
C25		U/25/651	2500	4	<b>0203A</b>	36,50	29,80	5,0	12	2
					<b>0203B</b>	37,00	29,80	5,3		
Jumper		DJ5T	2500	4	<b>0201A</b>	36,70	31,70	4,2	18	1
					<b>0201B</b>	37,00	31,70	4,5		
Jumper		DJ5	2500	4	<b>0202A</b>	36,70	31,70	4,2	14	1
					<b>0202B</b>	37,00	31,70	4,5		
<b>FSC Lublin (Daewoo)</b>										
Lublin		4C90	2400	4	<b>0205A</b>	36,10	30,80	4,8	12	1
					<b>0205B</b>	36,50	30,80	5,2		









# MOTO-SZLIF®

## komory wirowe

Model	Photo	Code engine	Engine Capacity cm <sup>3</sup>	qty cylinder	Moto Szlif Nr	K ∅ mm	T ∅ mm	H ∅ mm	opening length (mm)	poz
<b>DAF</b>										
400D 400EA/55 400TD 400ET/70		XD3 XD3T	2500	4	<b>0204A</b>	36,60	31,80	4,2	12,5	1
					<b>0204B</b>	37,00	31,80	4,5		
<b>Fiat</b>										
Scudo D/TD Ducato TD		XUD9 XUD9TE	1900	4	<b>0104A</b>	32,15	28,10	4,2	11,5	1
					<b>0104B</b>	32,65	28,10	4,5		
Ulysse		XUD11 BTE	2100	4	<b>0205C</b>	34,10	29,80	4,2	12	1
					<b>0205D</b>	34,50	29,80	4,5		
Ducato			2500	4	<b>0203C</b>	36,20	30,30	4,8	12	1
					<b>0203D</b>	36,70	30,30	5,0		
Dukato			2800	4	<b>1103A</b>	38,80	32,60	5,7	14,5	1
					<b>1103B</b>	39,00	33,10	6,0		
<b>Ford</b>										
FiestaD EskortD OrionD CourierD MondeoD SierraD		RTC RTA RFM	1800	4	<b>0104C</b>	31,40	27,50	5,2	11,5	1
					<b>0104D</b>	31,80	27,50	5,5		
Econovan Courier Escort Tempo		RF	2000	4	<b>0601A</b>	35,15	30,00	5,8	13	1
					<b>0601B</b>	35,50	30,00	6,2		
SierraD SierraLD SierraGLD		XD2	2300	4	<b>0205E</b>	35,15	28,80	4,3	12	1
					<b>0205F</b>	35,50	28,80	4,5		









# MOTO-SZLIF®

## komory wirowe

Model	Photo	Code engine	Engine Capacity cm <sup>3</sup>	qty cylinder	Moto Szlif Nr	K ∅ mm	T ∅ mm	H ∅ mm	opening length (mm)	poz
<b>Ford</b>										
Bronco IITD Ranger 2WD Ranger 4WD		4D55T	2300	4	<b>0901A</b>	34,10		24,80	19	1
					<b>0901B</b>	34,60		25,20		
GranadaD ScorpioD ScorpioLD		XD3	2500	4	<b>0204A</b>	36,60	31,90	4,3	12,5	1
					<b>0204B</b>	37,00	31,90	4,5		
Scorpio D Granada D		VM25 T VM923 B	2400	4	<b>0205G</b>	35,60	30,40	4,8	12	1
					<b>0205H</b>	36,00	30,40	5,0		
Escort Fiesta Orion		LTB LTA/LTC	1600	4	<b>0803E</b>	30,60	26,50	4,3	11,5	1
<b>0803F</b>	31,10	26,50	4,5							
<b>Hyundai</b>										
Lantra		XUD9A/L	1900	4	<b>0104A</b>	32,15	28,10	4,2	11,5	1
					<b>0104B</b>	32,65	28,10	4,5		
Hyundai H100 Hyundai H1		4D56 D4BA	2500	4	<b>0902A</b>	34,10		24,8	17	3
					<b>0902B</b>	34,60		25,2		
Hyundai H100 Hyundai H1 D/TD		4D56/ D4BA 4D56T/ D4BA 4D55	2500	4	<b>0901A</b>	34,10		24,8	19	
			2300		<b>0901B</b>	34,60		25,2		
<b>IFA</b>										
Multikar 25			1997	4	<b>1305A</b>	32,10		9,2	8	
					<b>1305B</b>	32,50		9,5		

# MOTO-SZLIF®









## komory wirowe

Model	Photo	Code engine	Engine Capacity cm <sup>3</sup>	qty cylinder	Moto Szlif Nr	K ∅ mm	T ∅ mm	H ∅ mm	opening length (mm)	poz
<b>Isuzu</b>										
Gemini I-Mark		4EC1	1500	4	0803A	30,10	25,40	4,3	11,5	1
					0803B	30,50	25,40	4,6		
Gemini TD I-Mark TD		T4EC1	1500	4	0801A	30,10	25,50	4,3	13,5	1
					0801B	30,50	25,50	4,6		
<b>Iveco</b>										
Ducato			2500	4	0203C	36,20	30,30	4,8	12	1
					0203D	36,70	30,30	5,0		
Daily New Daily			2800	4	1103A	38,80	32,60	5,7	14,5	1
					1103B	39,00	33,10	6,0		
<b>Jeep</b>										
Cherokee D/TD		J8S Turbo	2100	4	1202A	35,65	30,00	4,5	13	1
					1202B	36,10	30,00	4,8		
Grand Cherokee D/TD		VM25 T VM	2400	4	0205G	35,60	30,40	4,8	12	1
					0205H	36,00	30,40	5,0		
<b>KIA</b>										
Besta		R2	2200	4	0601C	36,10	31,00	5,8	13	1
					0601D	36,50	31,00	6,2		
K2700			2700	4	1102A	39,10	31,60	5,7	13,5	3
					1102B	39,60	31,60	6,2		





# MOTO-SZLIF®

## komory wirowe

Model	Photo	Code engine	Engine Capacity cm <sup>3</sup>	qty cylinder	Moto Szlif Nr	K ∅ mm	T ∅ mm	H ∅ mm	opening length (mm)	poz
<b>KIA</b>										
Esportage TD		RF	2000	4	0601A	35,15	30,00	5,8	13	1
					0601B	35,50	30,00	6,2		
<b>Lancia</b>										
Zeta 12V		XUD11BTE (P8C)	2100	4	0205C	34,10	29,80	4,2	12	1
					0205D	34,50	29,80	4,5		
<b>Land Rover</b>										
Range Rover		M51	2500	6	0802A	31,00	27,50	4,3	11	1
					0802B	31,50	27,50	4,6		
<b>Mazda</b>										
323		4EE1-T	1700	4	0701A	33,10	26,70	4,3	13,8	1
					0701B	33,50	26,70	4,6		
626		RF	2000	4	0601A	35,15	30,00	5,8	13	1
					0601B	35,50	30,00	6,2		
E2200		R2	2200	4	0601C	36,10	31,00	5,8	13	1
					0601D	36,50	31,00	6,2		
626 RF7		RF-Cx Complex	2000	4	0602A	36,10	31,00	5,8	13	1
					0602B	36,50	31,00	6,2		
626		R2	2000	4	0502A	35,60	31,00	5,8	13,7	2
					0502B	36,10	31,00	6,2		







# MOTO-SZLIF®

## komory wirowe

Model	Photo	Code engine	Engine Capacity cm <sup>3</sup>	qty cylinder	Moto Szlif Nr	K Ø mm	T Ø mm	H Ø mm	opening length (mm)	poz
<b>Mitsubishi</b>										
Carisma		F8Q	1900	4	<b>0302A</b>	37,60	32	4,6	11,5	1
					<b>0302B</b>	38,10	32	4,8		
Space Wagon Colt/Lancer Galant		4D65	1800	4	<b>1001A</b>	31,10		21,8	15	
					<b>1001B</b>	31,60		22,2		
Lancer Galnt Space Runner Space Wagon		4D68	2000	4	<b>1002A</b>	31,10		21,8	14,8	
					<b>1002B</b>	31,60		22,2		
Montero Pajero D/TD L 300 Canter Galant		4D56 4D55	2500 2300	4	<b>0901A</b>	34,10		24,8	19	
					<b>0901B</b>	34,60		25,2		
Montero Pajero TD L 300 Canter		4D56	2500	4	<b>0902A</b>	34,10		24,8	17	3
					<b>0902B</b>	34,60		25,2		
Pajero TD/D Shogun TD Canter T/TD		4M40 4M40T	2800	4	<b>0903A</b>	34,10		13,4	18	
					<b>0903B</b>	34,50		13,9		
<b>Opel</b>										
AstraD/TD VectraD KadetD		17YD X17DTD 17D/DR	1700	4	<b>0104E</b>	32,00	26,70	4,2	11,5	1
					<b>0104F</b>	32,50	26,70	4,5		
BelmontD Cavalier KadetED AsconaC		16D 16DA	1600	4	<b>0104E</b>	32,00	26,70	4,2	11,5	1
					<b>0104F</b>	32,50	26,70	4,5		





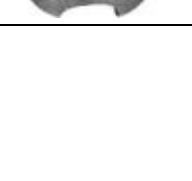

# MOTO-SZLIF®

## komory wirowe

Model	Photo	Code engine	Engine Capacity cm <sup>3</sup>	qty cylinder	Moto Szlif Nr	K ∅ mm	T ∅ mm	H ∅ mm	opening length (mm)	poz
<b>Opel</b>										
Omega Record		23D/TD 23YD	2300	4	<b>0301A</b>	34,10	29,80	4,2	12	1
					<b>0301B</b>	34,50	29,80	4,5		
CorsaD AstraD VectraTD Kedet Combo		TC4EE1 X17DT	1700	4	<b>0701A</b>	33,10	26,7	4,3	13,8	1
					<b>0701B</b>	33,50	26,7	4,6		
					<b>0701C</b>	35,10	28,7	4,3	13,8	1
					<b>0701D</b>	35,50	28,7	4,6		
Astra Corsa Combo		4EE1	1700	4	<b>0702A</b>	33,10	26,7	4,3	11,5	1
					<b>0702B</b>	33,50	26,7	4,6		
CorsaD Nova		4EC1	1500	4	<b>0702C</b>	35,10	28,7	4,3	11,5	1
					<b>0702D</b>	35,50	28,7	4,6		
Corsa-Nova Corsa – B Kadet – E		T4EC1	1500	4	<b>0801A</b>	30,10	25,50	4,3	13,5	1
					<b>0801B</b>	30,50	25,50	4,6		
Corsa B		4EC1	1500	4	<b>0803A</b>	30,10	25,50	4,3	11,5	1
					<b>0803B</b>	30,50	25,50	4,6		
Frontiera D/TD		VM	2400	4	<b>0205G</b>	35,60	30,40	4,8	12	1
					<b>0205H</b>	36,00	30,40	5,0		
Omega TD		M51	2500	6	<b>0802A</b>	31,00	27,50	4,3	11	1
					<b>0802B</b>	31,50	27,50	4,6		







# MOTO-SZLIF®

## komory wirowe

Model	Photo	Code engine	Engine Capacity cm <sup>3</sup>	qty cylinder	Moto Szlif Nr	K Ø mm	T Ø mm	H Ø mm	opening length (mm)	poz
<b>Perkins</b>										
		4.108 4.99	1760 1620	4	<b>1301A</b> <b>1301B</b>	31,85 32,30		9,7 10,0	11	2
Idem		4.108 4.99 4.154	1760 1620 2520	4	<b>1302A</b> <b>1302B</b>	31,85 32,30		9,7 10,0	14	2
		4.165 4.154	2710 2520	4	<b>1303A</b> <b>1303B</b>	34,85 35,30		10,8 11,5	15	2
		100.104. .19	1900	4	<b>0401C</b> <b>0401D</b>	32,10 32,50	27,40 27,40	4,3 4,6	12	1
FERGUSON M35		A 3.152	2500	4						1
BARRREIROS			2500	4	<b>1304A</b> <b>1304B</b>	31,90 32,30		9,9 10,3	13	1









# MOTO-SZLIF®

## komory wirowe

Model	Photo	Code engine	Engine Capacity cm <sup>3</sup>	qty cylinder	Moto Szlif Nr	K ∅ mm	T ∅ mm	H ∅ mm	opening length (mm)	poz
<b>Peugeot</b>										
305GLD/SRD 309GLD/SRD 309XLD/XRD 309GRD/D 205D 405GLD 405D/TD 306D/TD 806D/TD Boxer		XUD9 XUD9A XUD9A/L XUD9TE	1900	4	<b>0104A</b>	32,15	28,10	4,2	11,5	1
					<b>0104B</b>	32,65	28,10	4,5		
J5D		U/25/651	2500	4	<b>0203A</b>	36,50	29,80	5,0	12	2
					<b>0203B</b>	37,00	29,80	5,3		
505D 505GRD 505SRD J7D J9D		XD2	2300	4	<b>0205E</b>	35,15	28,80	4,3	12	1
					<b>0205F</b>	35,50	28,80	4,5		
505GRD 505SRD J9D 505GTD 505TDE 606GTD		XD3 XD3T XD3TE	2500	4	<b>0204A</b>	36,60	31,90	4,3	12,5	1
					<b>0204B</b>	37,00	31,90	4,5		
Boxer		DJ5T	2500	4	<b>0201A</b>	36,70	31,70	4,2	18	1
					<b>0201B</b>	37,00	31,70	4,5		
Boxer		DJ5/T9A	2500	4	<b>0202A</b>	36,70	31,70	4,2	14	1
					<b>0202B</b>	37,00	31,70	4,5		
605 406 806		XUD11	2100	4	<b>0205C</b>	34,10	29,80	4,2	12	1
					<b>0205D</b>	34,50	29,80	4,5		
			1400	4						1







# MOTO-SZLIF®

## komory wirowe

Model	Photo	Code engine	Engine Capacity cm <sup>3</sup>	qty cylinder	Moto Szlif Nr	K ∅ mm	T ∅ mm	H ∅ mm	opening length (mm)	poz
<b>Pegaso</b>										
Ekus D/TD		DW DV	2400	6	<b>0101A</b>	32,10	27,40	4,3	11,5	1
					<b>0101B</b>	32,20	27,40	4,4		
					<b>0101C</b>	32,50	27,40	4,6		
<b>Renault</b>										
Espace Megane Laguna		G8T	2200	4	<b>0204C</b>	36,70	29,70	4,6	12,5	1
					<b>0204D</b>	37,20	29,70	4,8		
R19D R5D/VAN Megane 1,9D Clio 1,9D Kangoo		F8Q	1900	4	<b>0302A</b>	37,60	32,00	4,6	11,5	1
					<b>0302B</b>	38,10	32,00	4,8		
R19TD CHAMADE Megane-Scenic Kangoo		F8Q Turbo	1900	4	<b>0303A</b>	37,60	32,00	4,6	12	1
					<b>0303B</b>	38,10	32,00	4,8		
Espace, R18D Laguna, R21D R21D Nevada Trafic, R25D Safrane		J8S	2100	4	<b>1201A</b>	35,65	30,00	4,5	11,5	1
					<b>1201B</b>	36,10	30,00	4,8		
Espace, R18TD Laguna R21TD Nevada R21TD, R25TD Safrane		J8S Turbo	2100	4	<b>1202A</b>	35,65	30,00	4,5	13	1
					<b>1202B</b>	36,10	30,00	4,8		
<b>Rover</b>										
218 SD 418 SLD		XUD9A XUD9	1900	4	<b>0104A</b>	32,15	28,10	4,2	11,5	1
					<b>0104B</b>	32,65	28,10	4,5		
Range Rover 2500 TD 2400 TD		VM	2500 2400	4	<b>0205G</b>	35,60	30,40	4,8	12	1
					<b>0205H</b>	36,00	30,40	5,0		

# MOTO-SZLIF®

## komory wirowe

Model	Photo	Code engine	Engine Capacity cm <sup>3</sup>	qty cylinder	Moto Szlif Nr	K Ø mm	T Ø mm	H Ø mm	opening length (mm)	poz
<b>Seat</b>										
ToledoD IbizaD ToledoTD IbizaTD		1Y AAZ	1900	4	0102A	32,10	27,90	4,3	12,5	1
					0102B	32,20	27,90	4,4		
					0102C	32,50	27,90	4,6		
<b>Skoda</b>										
Octavia D/TD Fabia D/TD			1900	4	0102A	32,10	27,90	4,3	12,5	1
					0102B	32,20	27,90	4,4		
					0102C	32,50	27,90	4,6		
<b>Ssang Yong</b>										
Korando Family		XD3	2500	4	0204A	36,60	31,90	4,3	12,5	1
					0204B	37,00	31,90	4,5		
<b>Suzuki</b>										
Vitara D/TD		XUD9	1900	4	0104A	32,15	28,10	4,2	11,5	1
					0104B	32,65	28,10	4,5		
Vitara		R2	2200	4	0601C	36,10	31,00	5,8	13	1
					0601D	36,50	31,00	6,2		
<b>Talbot</b>										
Horizon		XUD9	1900	4	0104A	32,15	28,10	4,2	11,5	1
					0104B	32,65	28,10	4,5		
Tagora TD		XD2S	2300	4	0205E	35,15	28,80	4,3	12	1
					0205F	35,50	28,80	4,5		

# MOTO-SZLIF®









## komory wirowe

Model	Photo	Code engine	Engine Capacity cm <sup>3</sup>	qty cylinder	Moto Szlif Nr	K Ø mm	T Ø mm	H Ø mm	opening length (mm)	poz
<b>Toyota</b>										
Carina Corolla Lite-Ace Camry		1C	1800	4	<b>0401A</b>	31,65	27,40	5,3	12	3
					<b>0401B</b>	32,20	27,40	5,5		
Carina		2C	2000	4	<b>0402A</b>	31,60	27,40	5,3	12,5	3
					<b>0402B</b>	32,10	27,40	5,5		
Carina		2C-T	2000	4	<b>0403A</b>	31,60	27,40	5,3	14	3
					<b>0403B</b>	32,10	27,40	5,5		
Hi-Ace Hi-Lux Landcruiser		2LT	2446	4	<b>0501A</b>	36,70	33,80	6,2	16	3
					<b>0501B</b>	37,20	33,80	6,5		
PickUp Turbo		2LT-NT	2446	4	<b>0501C</b>	36,70	33,50	6,2	16	3
					<b>0501D</b>	37,20	33,50	6,5		
2500 D/TD		VM	2500	4	<b>0205G</b>	35,60	30,40	4,8	12	1
					<b>0205H</b>	36,00	30,40	5,0		
Land Cruiser TD 4 Runner TD		1KZ-TE	3000	4	<b>1101A</b>	38,80	34,10	6,3	16,5	3
					<b>1101B</b>	39,00	34,60	6,6		











# MOTO-SZLIF®

## komory wirowe

Model	Photo	Code engine	Engine Capacity cm <sup>3</sup>	qty cylinder	Moto Szlif Nr	K Ø mm	T Ø mm	H Ø mm	opening length (mm)	poz
<b>Vauxhall</b>										
Frontera		VM	2400	4	<b>0205G</b>	35,60	30,40	4,8	12	1
					<b>0205H</b>	36,00	30,40	5,0		
Corsa D		4EC1	1500	4	<b>0803A</b>	30,10	25,40	4,3	11,5	1
					<b>0803B</b>	30,50	25,40	4,6		
Corsa TD		T4EC1	1500	4	<b>0801A</b>	30,10	25,50	4,3	13,5	1
					<b>0801B</b>	30,50	25,50	4,6		
Astra D Belmont D Cavalier D Kadett E D Ascona C		16D 16DA	1600	4	<b>0104E</b>	32,00	26,70	4,2	11,5	1
					<b>0104F</b>	32,50	26,70	4,5		
Ascona D Vectra D Kadett D		17YD	1700	4	<b>0104E</b>	32,00	26,70	4,2	11,5	1
					<b>0104F</b>	32,50	26,70	4,5		
Combo D Corsa D		X17D 4EE1	1700	4	<b>0702A</b>	33,10	26,7	4,3	11,5	1
					<b>0702B</b>	33,50	26,7	4,6		
Astra TD Vectra TD		X17TD TC4EE1	1700	4	<b>0701A</b>	33,10	26,7	4,3	13,8	1
					<b>0701B</b>	33,50	26,7	4,6		
Omega TD		M51D	2500	6	<b>0802A</b>	31,00	27,50	4,3	11	1
					<b>0802B</b>	31,50	27,50	4,6		

# MOTO-SZLIF®

## komory wirowe

Model	Photo	Code engine	Engine Capacity cm <sup>3</sup>	qty cylinder	Moto Szlif Nr	K Ø mm	T Ø mm	H Ø mm	opening length (mm)	poz
<b>Volkswagen</b>										
GolfD/TD PusatD/TD JettaD/TD TransporterD/TD CaddyD/TD SantanaD/TD RabbitD/TD		JK/CY JP/JR CR/JX	1600	4	<b>0101A</b>	32,10	27,40	4,3	11,5	1
					<b>0101B</b>	32,20	27,40	4,4		
					<b>0101C</b>	32,50	27,40	4,6		
Transporter Caravelle		KY	1700	4	<b>0101A</b>	32,10	27,40	4,3	11,5	1
					<b>0101B</b>	32,20	27,40	4,4		
					<b>0101C</b>	32,50	27,40	4,6		
GolfD/TD SharanTD PassatTD VentoD/TD VariantTD TransporterD/TD		1Y AAZ ABL 1X AFE AEY	1900	4	<b>0102A</b>	32,10	27,90	4,3	12,5	1
					<b>0102B</b>	32,20	27,90	4,4		
					<b>0102C</b>	32,50	27,90	4,6		
LT D/TD		DV DW CP 1G 1S ACT	2400	6	<b>0101A</b>	32,10	27,40	4,3	11,5	1
					<b>0101B</b>	32,20	27,40	4,4		
					<b>0101C</b>	32,50	27,40	4,6		
Transporter T4		AAB AJA	2400	5	<b>0101D</b>	32,10	27,90	4,3	11,5	1
					<b>0101E</b>	32,20	27,90	4,4		
					<b>0101F</b>	32,50	27,90	4,6		
Polo 1,3 D Golf D/TD Golf, Passat		MN ME, MF, SB CK	1300 1600 1500	4	<b>0803A</b>	30,10	25,40	4,3	11,5	1
					<b>0803B</b>	30,50	25,40	4,6		
<b>Volvo</b>										
240 D+TD 740 D+TD 760 D+TD 940 GLE 969 TD		D24 D24T	2400	6	<b>0101A</b>	32,10	27,40	4,3	11,5	1
					<b>0101B</b>	32,20	27,40	4,4		
					<b>0101C</b>	32,50	27,40	4,6		
460 TD 440 TD S40 V40		D19T D4192	1900	4	<b>0302A</b>	37,60	32	4,6	11,5	1
					<b>0302B</b>	38,10	32	4,8		

# MOTO-SZLIF®

---

**MS1** Klucz do montażu nakrętek mocujących komorę wirową głowicy Mercedes.  
Spanner, Schlüssel.



**MS2** Nakrętki mocujące komorę wirową w głowicy Mercedes.  
Gewinding Vorkammer an Zylinderkopf.



M 35x1,5  
M 36x1,5  
M 37x1,5

**MS3** Gwintownik do nakrętek komór wirowych Mercedes  
Reamer (pre + finish)



M 35x1,5  
M 36x1,5  
M 37x1,5

**MS5** Poglębiacz pod gwint M37



**MS4** Kontrolka termiczna do głowic.

